

A series Mini Range pallet truck II specification

Distinguishing mark	1.1	Manufacturer	HANGCHA GROUP CO.,LTD.
	1.2	Manufacturer's type designation	CBD15-A2MC1
	1.4	Operator type: hand, pedestrian, standing, seated, order-picker	Pedestrian
	1.5	Rated capacity/rated load	Q (kg) 1500
	1.6	Load centre distance	c (mm) 600
Weight	1.8	Load distance, centre of drive axle to fork	x (mm) 960
	1.9	Wheelbase	y (mm) 1285
Tyres, chassis	2.1	Service Weight(Including battery)	kg 220
		Battery weight	kg 50
	3.1	Tyres: solid rubber, superelastic, pneumatic, polyurethane	PU
	3.2	Tyre size, front	Φ210x70
	3.3	Tyre size, rear	2×Φ80x64
Dimensions	3.4	Additional wheel (dimensions)	Φ70x40
	3.5	Wheels, number front / rear (x = driven wheels)	1x+2/4
	3.6	Tread, front	b ₁₀ (mm) 404
	3.7	Tread, rear	b ₁₁ (mm) 400
	4.4	Lift	h ₃ (mm) 120
	4.15	Fork height,lowered	h ₁₃ (mm) 80
	4.19	Overall length	l ₁ (mm) 1669
	4.21	Overall width	b ₁ (mm) 568
	4.22	Fork dimensions	s/e/l (mm) 50/160/1150
	4.25	Distance between fork-arms	b ₅ (mm) 560/680
Performance data	4.32	Ground clearance, centre of wheelbase	m ₂ (mm) 30
	4.34.1	Aisle width for pallets 1000 x 1200 crossways	A _{st} (mm) 1850 ^①
	4.34.2	Aisle width for pallets 800 x 1200 lengthways	A _{st} (mm) 1900 ^①
	4.35	Turning radius	W _a (mm) 1400 ^②
	5.1	Travel speed,laden/unladen	km/h 4.5/4.9
	5.2	Lift speed,laden/unladen	m/s 0.050/0.060
	5.3	Lowering speed,laden/unladen	m/s 0.040/0.045
Electric engine	5.8	Max Gradeability,laden/unladen	% 6/15
	6.1	Drive motor rating S2 60 min	kW 0.65
	6.2	Lift motor rating at S3 15%	kW 0.8
	6.4	Battery voltage,rated capacity	V/Ah 2x12/70
	8.1	Type of drive control	DC
9.1	Manufacturer	Curtis	

Note: 1), VDI 2198: +358mm 2), VDI 2198: +200mm 3), When fork lowered,+60mm

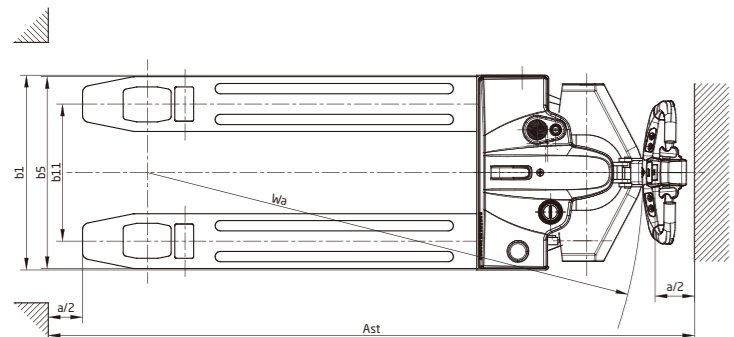
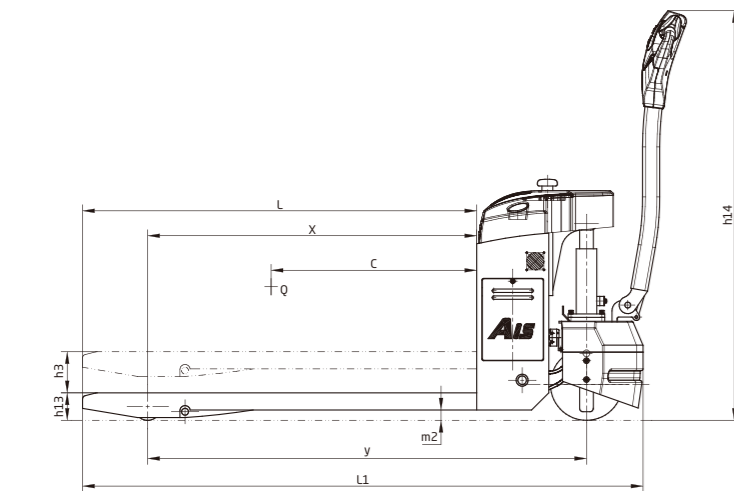

ZHEJIANG HANGCHA IMP. & EXP. CO., LTD.

Factory site: 666 Xiangfu Road,
Hangzhou, Zhejiang, China (311305)

Tel: +86-571-88926735 88926755
Fax: +86-571-88926789 88132890

sales@hcforklift.com
www.hcforklift.com



Follow us on
Facebook



Follow us on
YouTube



Follow us on
WeChat



ISO14001
ISO14001:2015



ISO9001
ISO9001:2015



HANGCHA trucks conform to the European Safety Requirements.

HANGCHA GROUP CO., LTD. reserves the right to make any changes without notice concerning colors, equipment, or specifications detailed in this brochure, or to discontinue individual models. The colors of trucks, delivered may differ slightly from those in brochures.

2018 VERSION 1,COPYRIGHT 2018/08



A series pallet truck mini range II

with capacities of 1,500kg

The World of Hangcha



A series pallet truck mini range II

The A series pallet truck mini range II has been engineered to be both powerful and flexible to meet the requirements of many demanding applications. Whether it's supermarket work, delivery service, stock replenishment or heavy manufacturing, the A series pallet truck mini range II has the strength and durability to minimise your total cost of ownership.



Easy/ Efficiency/ Economy

Appearance

- / A series pallet truck mini range II applied professional industrial design, stream lines, and compact, and fully ergonomic consideration, in line with the latest design trends.
- / Applied steel stamping and injection molding processes, which is robust, durable, and also environmental compliance.

High Performance

- / Rated capacity 1500kg, meet the needs of the majority of customers.
- / Powered by traction motor not only has good acceleration and perfect performance, but also low heat.
- / Latest CURTIS control system, precise and smooth.
- / Regenerative braking for battery recovery during travel speed reduction, anti-slope on gradient.
- / All key parts such as tiller, switches, connectors, battery indicator and hour meter all adopt the famous brand.

Comfort

- / Simple and beautiful tiller made by REMA designed to make the operator feel comfortable, all the operation can be completed by one hand.
- / Optimized designing structure to offer a good visibility and easy entrance of the pallet.
- / Built-in charger and maintenance free gel battery adopted to provide convenient usage.
- / The compact body and semicircular design provide an ideal operation in limited space, and the ability of walking upright greatly increases the convenience in the container.
- / Standard fork height 80mm, equipped the guide device easy to get in pallets (including sealing pallets).
- / Side battery change is standard feature.

Reliability

- / 5-pivot design provide longer working life.
- / Imported waterproof connectors, all wires and cables are protected, greatly improve the reliability of the electric system.
- / Top quality hydraulic power unit applied to provide low noise, low vibration, smooth lifting and landing reliable operation.
- / Punch formed forks to provide more strength and tip guide to provide higher efficient operation.
- / Using non-contact proximity switch, improves safety and reliability.



Standard specification

- / Permanent magnet drive motor
- / CURTIS permanent magnet controller
- / Emergency switch
- / Multi-function battery indicator
- / PU wheel
- / 1150mm fork length
- / 560mm outside fork width
- / Electronic lifting limitation
- / Non-contact proximity switch
- / Tiller made by REMA
- / Horn
- / Maintenance free battery
- / Internal charger
- / Walking upright
- / Guide device
- / Additional wheel
- / Tandem load wheel

Options

- / Different length of fork
- / Different width of outside fork
- / Single load wheel



Rema tiller head



Auxiliary wheels are equipped to have better stability



Modern outline design

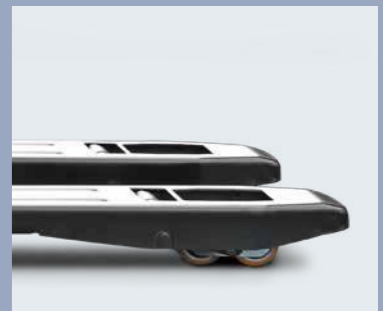

Tandem load wheel

Safety

- / Three braking system of regenerative braking, reverse current braking, parking brake, insures the safe operation.
- / Anti-slope on gradient can keep the safety.
- / The emergency button on the tiller head can effectively avoid the harm to the driver.
- / The standard equipped electronic lifting limitation protect the pump motor from damaging dramatically and more energy saving.

Maintenance

- / Built-in charger and maintenance free gel battery, you don't need to worry about them.
- / Integrated battery indicator, hour meter and self-diagnostic instrument.
- / Full opened hood, easy accessibility of all components, is easy for service.
- / All shafts installed lubricated shaft sleeve and oil cup, provide convenient maintenance and long service life.