



ZHEJIANG HANGCHA IMP. & EXP. CO., LTD.

Factory site: 666 Xiangfu Road,
Hangzhou, Zhejiang, China (311305)

Tel: +86-571-88926735 88926755
Fax: +86-571-88926789 88132890

sales@hcforklift.com
www.hcforklift.com



Follow us on
Facebook



Follow us on
YouTube



Follow us on
WeChat



Download "Hangcha
Forklift" App



ISO14001
ISO14001:2015



ISO9001
ISO9001:2015



HANGCHA trucks conform
to the European Safety
Requirements.

2022 VERSION 2/COPYRIGHT 2022/04

HANGCHA GROUP CO., LTD. reserves the right to make any changes without notice concerning colors, equipment, or specifications detailed in this brochure, or to discontinue individual models. The colors of trucks, delivered may differ slightly from those in brochures.

XC Series 4-W Electric Forklift Truck With Lithium Iron-Phosphate

with capacity of 1,500 to 3,500kg



The World of Hangcha
SINCE 1956



INNOVATIVE SOLUTIONS NEW POWER NOW

The XC series new energy electric forklifts, covering range from 1.5t to 3.5t, is a series of products with new chassis launched by HANGCHA.

Innovative, reliable lithium-ion technology, which are developed jointly by HANGCHA and CATL. Battery cells and modules are from CATL, with reliable quality, exclusively for HANGCHA.

Rapid charging and opportunity charging ensure continuous availability of trucks.

Lightweight design, flexible, high level of energy efficiency, maintenance-free, long service life.



High capacity CATL battery packs

Integrated Battery Management System (BMS) continually monitors energy management and ensures reliable operation. HANGCHA provides Li-Ion battery with 5 years or 10000 hours warranty.

		Battery capacity (kW·h)
Pack1	1.5 - 1.8t: standard	80V*202Ah, 16.16Kwh
Pack2	1.5 - 1.8t: optional	80V*271Ah, 21.68Kwh
Pack3	2.0 - 2.5t: standard	80V*271Ah, 21.68Kwh
Pack4	2.0 - 2.5t: optional	80V*404Ah, 32.32Kwh
Pack5	3.0 - 3.5t: standard	80V*404Ah, 32.32Kwh
Pack6	3.0 - 3.5t: optional	80V*542Ah, 43.36Kwh

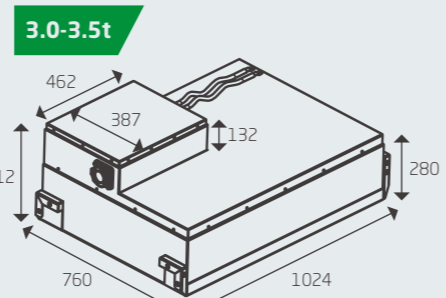
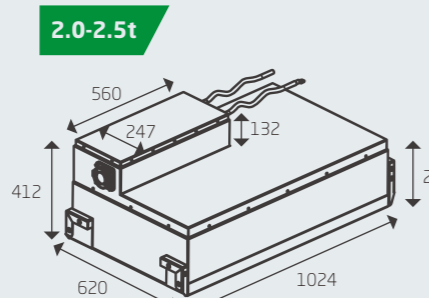
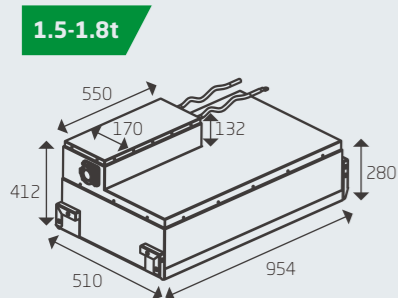

Excellent Ergonomic Design

- / The truck has a large operating space more than **50%** larger than the traditional electric truck.
- / The dashboard in the driver's cab is placed overhead and can be seen when the driver lifts her/his head, and the function buttons can be pressed easily.
- / For the optional integrated fingertip control system, the combined operating armrest integrates the emergency cut-off, horn and quadruple thumb switches, etc., is electrically controlled through the CAN bus and is highly reliable.
- / The enlarged brake pedal and appropriate regenerative braking function can effectively reduce the driver's fatigue.



Advantages



The rear axle is provided with a flexible suspension system (for standard configuration and automatic deceleration at turns improve the driver's comfort).

The high-frequency MOSFET integrated controller ensures smooth and accurate driving and lifting control, and has excellent speed regulation performance, good performance of electronic control matching the motor, functions of regenerative braking, reverse braking and anti-sliding on ramps, etc., and high safety and reliability.

The ultra-high power AC traction motor has a bridge structure. An ultra-high power AC pump motor is used. The system has high efficiency, complete protection functions, built-in speed and temperature sensors, and greatly improved reliability and life.

**RELIABLE
TRUCKS**



**5 YEARS
WARRANTY**

Easy operations and maintenance

Internal Components Protected with Fully-sealed Hood, controllers, motors electrical components, etc. are sealed from dust and water.

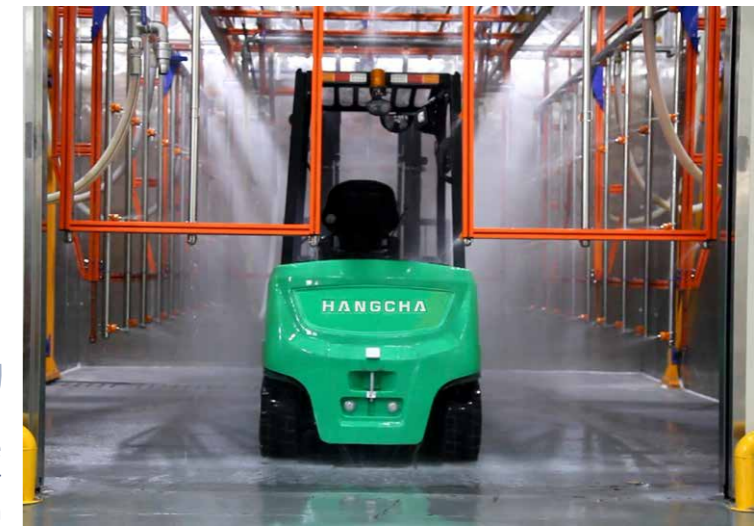

IPX4 water resistance rating, suitable for outdoor operation



The hood can be opened at a large angle facilitating the maintenance.





Safety

The optional OPS system can disable the lowering when the driver leaves the seat and enable high safety.

The standard configuration provides soft landing system. In addition, an optional lift buffering system is provided to protect the goods from falling and damaging the ground.

The handbrake can be optionally equipped with an alarm buzzer to prompt the driver to pull up the handbrake before leaving the truck.



Three horn buttons are provided, which are respectively on the driver's steering wheel, thumb switch equipped armrest (optional) and reverse armrest (optional), for alerting and protecting the surrounding people.



A PIN code should be provided before entering the system. 99 sets of PIN codes are available for the administrator. The truck is highly secured and irrelevant personnel cannot start the truck.



IP67 Protection Rating



Quick charge < 2.0h,
Working time > 9.0h

Comfort

Owing to the low center of gravity and good stability, the driver feels comfortable during turning.

The ergonomically designed adjustable steering wheel makes the driver feel good. The seat can be adjusted back and forth by 210mm. The operator can choose the best driving position.

New designed mast increases the wide view by 15%.

With friendly human-computer interfaces, the 4.33" True Color Screen instruments have good visibility and clear readings.

Silence, no pollution, energy saving and other advantages meet the environmental protection requirements.



Grammer fingertip (Optional)



Main Accessories

The main electrical components such as the controller, contactor, power plug, emergency cut-off switch, dashboard, accelerator, are all products of well-known world brands.

The emergency cut-off switch equipped for the standard configuration complies with EU regulations.

The truck has passed the CE certification.



Options

- / Lithium packs that can be replaced quickly
- / Pin code or card
- / Super elastic tyre
- / Marked solid tyre
- / Left and right rear view mirrors
- / Backup camera
- / Front/rear blue lights
- / Rear working lights
- / Charger (Titan or Schneider)
- / Reverse armrest
- / Hood with a key lock
- / OPS system
- / Lift buffering system
- / Multi way valves
- / Integrated fingertip control system
- / Widened / heightened load backrest
- / Widened fork carriage
- / Other length forks
- / Full free duplex mast
- / Full free triplex mast
- / Sideshifter
- / Other attachments
- / Grammer MSG531 suspension seat

Standard specification

- / Battery pack side roll out
- / Lithium packs with low temperature electric heating systems
- / High-power AC drive motor
- / High-power AC pump motor
- / Low noise gear pump
- / Multi-function color screen instrument cluster
- / Large integral rubber pedal pad
- / LED combination headlights, LED rear combination taillights
- / Stamped iron hood
- / Automatic deceleration at turns
- / Soft landing system
- / SPE power selection
- / Charging muzzle meeting national standards
- / Electronic cooling fan
- / Emergency cut-off switch
- / Reversing buzzer
- / Traction pin
- / Folder
- / Load sensing steering system
- / Duplex mast
- / Tilt cylinder jacket

XC Series 1.5~3.5t Electric Forklift

Distinguishing mark	HANGCHA GROUP CO.,LTD.							
	CPD15-XD4-SI16	CPD18-XD4-SI16	CPD20-XD4-SI26	CPD25-XD4-SI26	CPD30-XD4-SI26	CPD35-XD4-SI26	CPD35-XD4-SI26	
1.1	Manufacturer							
1.2	Manufacturers type designation							
1.3	Drive: electric (battery or mains), diesel, petrol, fuel gas							
1.4	Operator type: hand, pedestrian, standing, seated, order-picker							
1.5	Load capacity/rated load	Q (kg)	1500	1800	2000	2500	3000	3500
1.6	Load centre distance	c (mm)	500	500	500	500	500	500
1.8	Load distance, centre of drive axle to fork	x (mm)	405	410	444	444	482	482
1.9	Wheelbase	y (mm)	1380	1380	1520	1520	1650	1650
2.1	Service Weight	kg	2850	3080	3620	3920	4740	5080
2.2	Axle loading, laden front/rear	kg	3760/590	4255/625	5040/680	5820/700	6745/1095	7800/880
2.3	Axle loading, unladen front/rear	kg	1220/1630	1280/1800	1620/2000	1670/2250	2010/2730	2100/2980
3.1	Tyres: solid rubber, superelastic, pneumatic, polyurethane		Pneumatic	Pneumatic	Pneumatic	Pneumatic	Pneumatic	Super elastic
3.2	Tyre size, front		6.00-9NHS-10PR	21*8-9NHS-16PR	23*9-10	23*9-10	23*9-10	23*10-12
3.3	Tyre size, rear		5.00-8NHS-10PR	5.00-8NHS-10PR	18*7-8	18*7-8	18*7-8	200/50-10
3.5	Wheels, number front rear (x = driven wheels)		2x/2	2x/2	2x/2	2x/2	2x/2	2x/2
3.6	Tread, front	b10 (mm)	888	938	1068	1068	1068	1068
3.7	Tread, rear	b11 (mm)	915.5	915.5	960	960	960	960
4.1	Tilt of mast/fork carriage forward/backward	$\alpha/\beta(^{\circ})$	6/12	6/12	6/12	6/12	6/12	6/12
4.2	Height, mast lowered	h1 (mm)	1975	1975	2001	2001	2151	2151
4.3	Free lift	h2 (mm)	135	135	140	140	145	145
4.4	Lift	h3 (mm)	3000	3000	3000	3000	3000	3000
4.5	Height, mast extended	h4 (mm)	3955	3955	4040	4040	4135	4135
4.7	Height of overhead guard STD.	h6 (mm)	2080	2080	2100	2100	2100	2100
4.8	Seat height/stand height	h7 (mm)	1100	1100	1120	1120	1120	1120
4.12	Coupling height	h10 (mm)	420	420	430	430	430	430
4.19	Overall length	l1 (mm)	3056	3061	3370	3370	3550	3550
4.20	Length to face of forks	l2 (mm)	2136	2141	2300	2300	2480	2480
4.21	Overall width	b1 (mm)	1120	1138	1252	1252	1252	1298
4.22	Fork dimensions	s/e/l (mm)	35/120/920	35/120/920	40/122/1070	40/122/1070	45/122/1070	50/122/1070
4.23	Fork carriage DIN 15 173 --- ISO 2328, class/type A,B		ISO2328 2A	ISO2328 2A	ISO2328 2A	ISO2328 2A	ISO2328 3A	ISO2328 3A
4.24	Fork-carriage width	b3 (mm)	1000	1000	1038	1038	1100	1100
4.25	Distance between fork-arms	b5 (mm)	240/1000	240/1000	290/1100	290/1100	290/1100	290/1100
4.31	Ground clearance, laden, below mast	m1 (mm)	95	95	100	100	100	100
4.32	Ground clearance, centre of wheelbase	m2 (mm)	90	90	125	125	125	125
4.34.1	Aisle width for pallets 1000 x 1200 crossways	Ast (mm)	3555	3560	3734	3734	3955	3955
4.34.2	Aisle width for pallets 800 x 1200 Lengthways	Ast (mm)	3755	3760	3934	3934	4155	4155
4.35	Turning radius	Wa (mm)	1950	1950	2090	2090	2270	2270
4.36	Internal turning radius	b13 (mm)	620	620	655	655	730	730
5.1	Travel speed, laden/unladen	km/h	16/17	16/17	18/19	18/19	18/19	18/19
5.2	Lift speed, laden/unladen	m/s	0.430/0.460	0.420/0.460	0.450/0.560	0.430/0.560	0.390/0.540	0.370/0.540
5.3	Lowering speed, laden/unladen	m/s	0.520/0.480	0.520/0.480	0.450/0.420	0.470/0.420	0.450/0.420	0.470/0.420
5.5	Drawbar pull, laden/unladen	N	9000/10000	9500/11000	13000/14000	17000/18000	20000/21000	20500/21000
5.6	Max. Drawbar pull, laden/unladen	N	11000	12000	15000	19000	22000	23000
5.7	Gradeability, laden/unladen	%	20/20	20/20	20/20	20/20	20/20	20/20
5.8	Max. gradeability, laden/unladen	%	20/20	20/20	20/20	20/20	20/20	20/20
5.9	Acceleration time, laden/unladen (0-10m)	s	4.8/4.4	4.8/4.4	4.0/3.9	4.3/4.2	4.9/4.7	5.0/4.8
5.10	Service brake		Hydraulic	Hydraulic	Hydraulic	Hydraulic	Hydraulic	Hydraulic
5.11	Parking brake		Mechanical	Mechanical	Mechanical	Mechanical	Mechanical	Mechanical
6.1	Drive motor rating S2 60 min	kW	9AC	9AC	16.6AC	16.6AC	16.6AC	16.6AC
6.2	Lift motor rating at S3 15%	kW	16AC	16AC	25.5AC	25.5 AC	25.5AC	25.5AC
6.3	Battery voltage, Std.	V/Ah	80/202	80/202	80/271	80/271	80/404	80/404
	Battery voltage, Opt.	V/Ah	80/271	80/271	80/404	80/404	80/542	80/542
6.5	Min. battery weight	kg	160	160	220	220	320	320
	Max. battery weight	kg	195	195	280	280	380	380
8.1	Type of drive control		MOSFET/AC	MOSFET/AC	MOSFET/AC	MOSFET/AC	MOSFET/AC	MOSFET/AC
9.1	Manufacturer		INMOTION	INMOTION	INMOTION	INMOTION	INMOTION	INMOTION
10.1	Operating pressure for attachments	bar	145	145	175	175	175	175
10.2	Oil volume for attachments	l/min	65	65	65	65	65	65
10.3	Hydraulic Tank - capacity (drain & refill)	liter	25	25	28	28	28	28
10.7	Sound level at the driver's ear according to EN / DIN 12 053	dB (A)	75	75	75	75	75	75
10.8	Towing coupling, type DIN		Φ25 Pin	Φ25 Pin	Φ25 Pin	Φ25 Pin	Φ25 Pin	Φ25 Pin

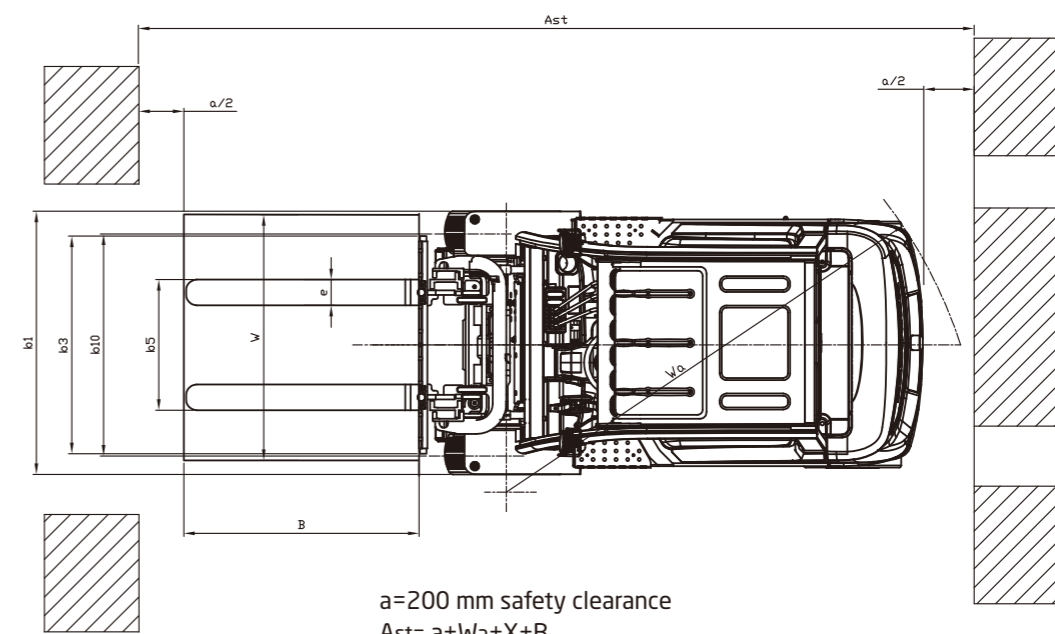
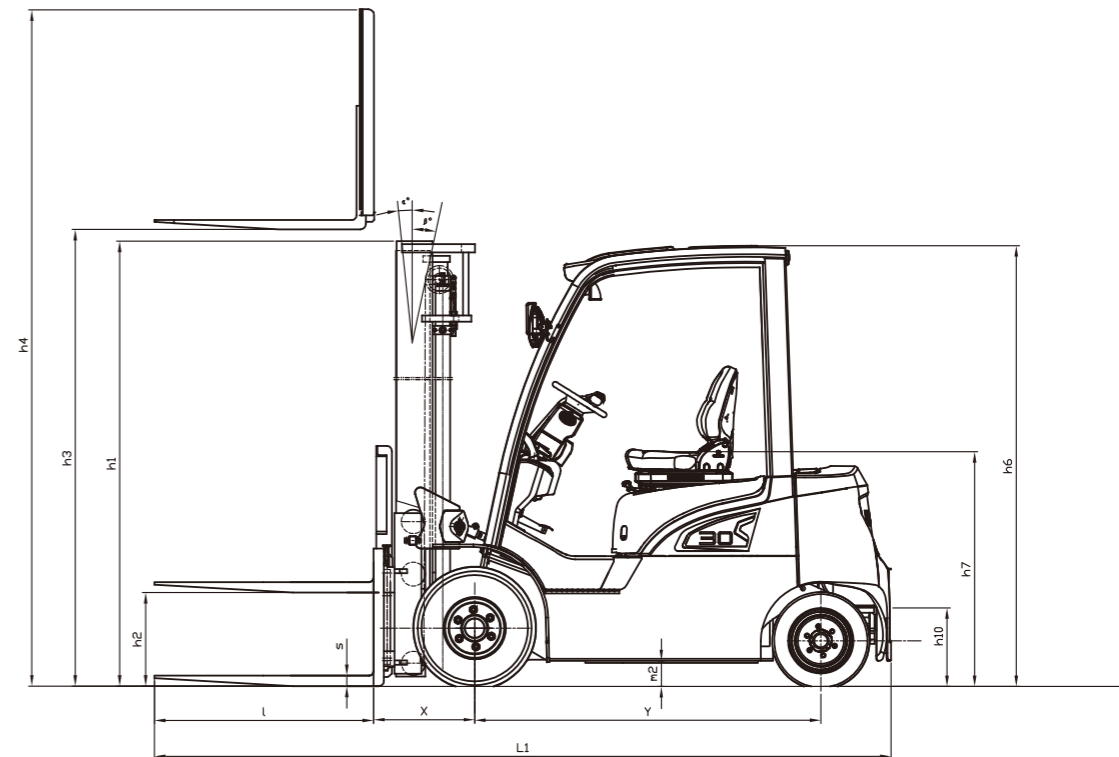

a=200 mm safety clearance
Ast= a+Wa+X+B

